

BONILLA

Designed to produce up to 300 cups of coffee per day, the Bonilla is ideal for offices or hotels where speed, ease of operation and ease of cleaning, (as well as great fresh coffee) are required.

Uses fresh beans, powdered milk and powdered chocolate



AUTOMATIC

KEY FEATURES

- Fully automatic coffee machine using fresh beans and powdered milk
- With 10 coffee selection buttons the Bonilla can produce a wide variety of drinks including espresso, cappuccino, latte, tea, hot chocolate... etc
- 3 internal canisters for hot chocolate, semi skimmed milk powder & tea (or decaf coffee powder)
- Adjustable serving sizes from 30ml / loz (espresso) to 350ml / 12oz (extra large selection)
- 2 independent boilers: one brass boiler for coffee giving perfect coffee temperature stability and one stainless steel boiler giving perfect ingredients brewing quality
- Coffee and ingredients are simultaneously brewed speeding up the drink delivery
- Backlit LCD display, showing common service requirements for the operator / user
- Automatic push button cleaning cycles ensure perfect hygiene in the coffee and ingredients circuits

SPECIFICATIONS

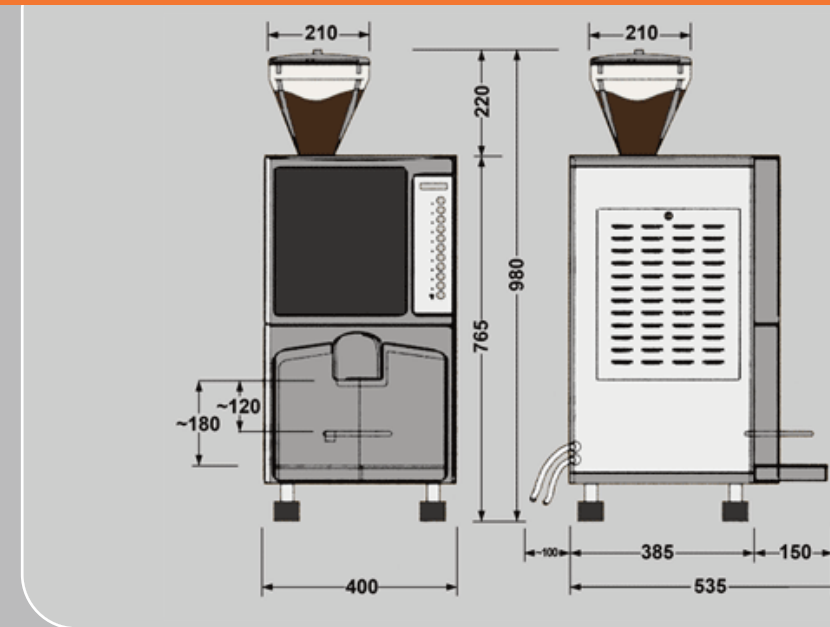

Boiler Capacity	Voltage	Heating Element	Water Mains Connection	Weight	Dimensions
11.4 litres	240 V / 50 Hz / 1	4100 W	1/8F	60 kg	W400 x H980 x D535

brasil coffee machines
www.brasil.co.uk 0845 4500500

Caffé Society - Unit 2 Lincoln Way
Sherburn-in-Elmet, Leeds LS25 6PJ
Web: www.caffesociety.co.uk
Email: info@brasil.co.uk Fax: 0845 4500499

SOLE UK IMPORTER
brasil
the Italian flair

